

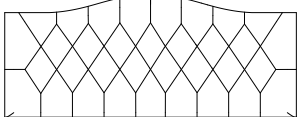

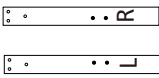

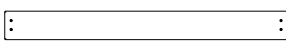



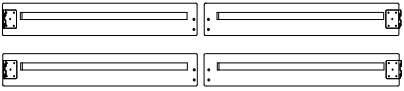

# 52002 KING BED

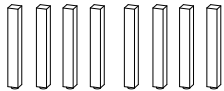
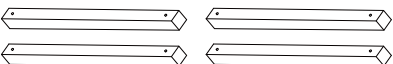
E1340022, E1340023, E1340024

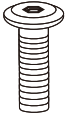
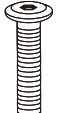
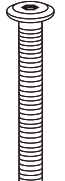
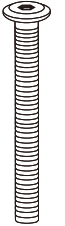
## Components

-  **A** X 1 pc
-  **B** X 1 set
-  **C** X 1 pc
-  **D** X 2 pcs
-  **E** X 2 sets
-  **F** X 2 pcs
-  **G** X 2 pcs
-  **H** X 8 pcs
-  **I** X 4 pcs

## Hardware

-  **J** M8X20 8 pcs
-  **K** M6X25 8 pcs
-  **L** M6X50 6 pcs
-  **M** M6X60 8 pcs
-  **N** M4X32 8 pcs
-  **O** M6 14 pcs
-  **P** M6 14 pcs
-  **Q** M4 1 pc
-  **R** M5 1 pc

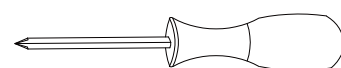

PHILLIPS SCREWDRIVER  
REQUIRED  
(NOT INCLUDED)

# PLEASE CONTACT US FOR RETURNS AND OTHER QUESTIONS

---

Email our support team at: [orders@rizebeds.com](mailto:orders@rizebeds.com)

Or call us at: 844-545-8865

Parts are inside the headboard  
in the compartment located  
on the back of the headboard

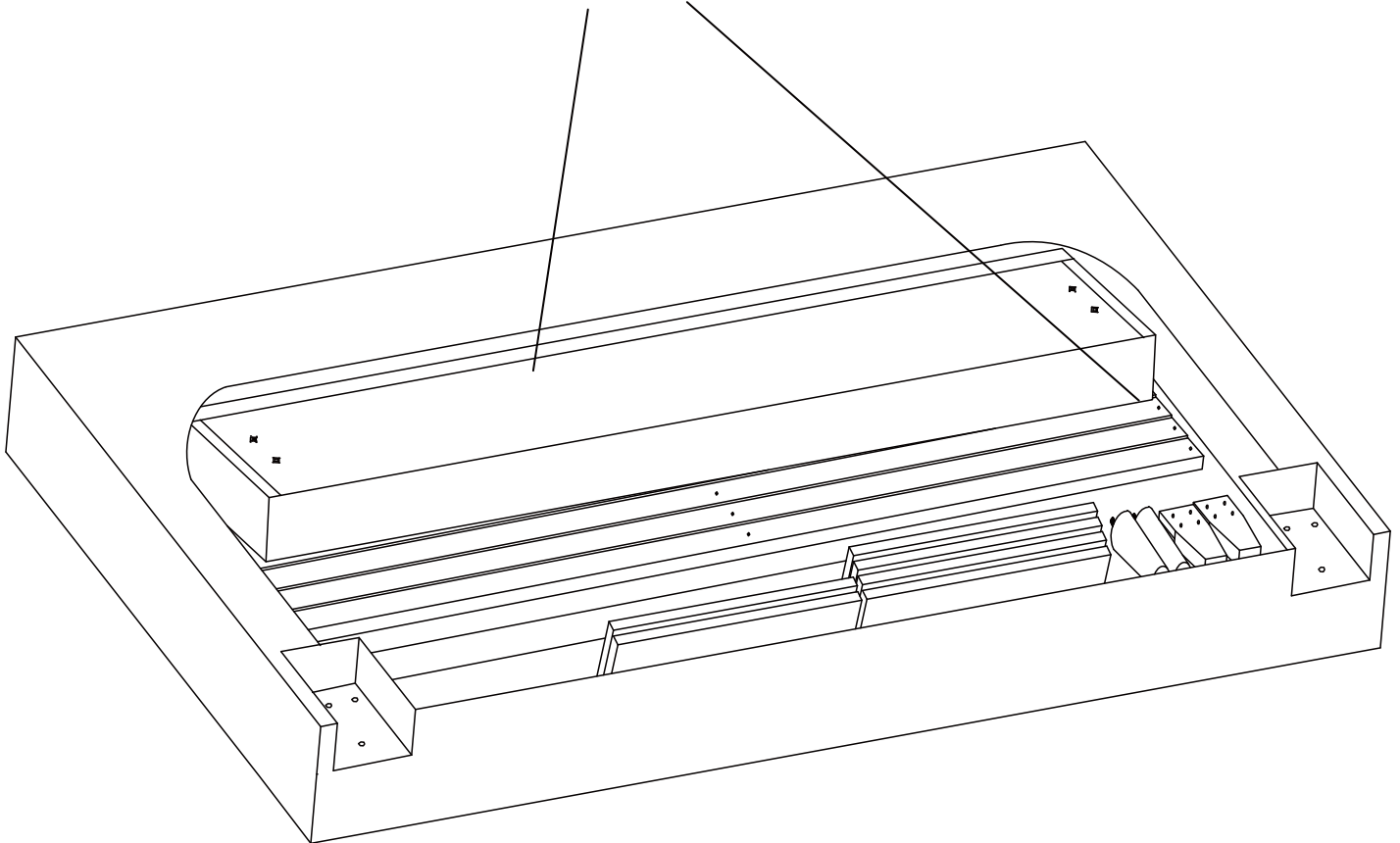

# Remove parts from headboard compartment

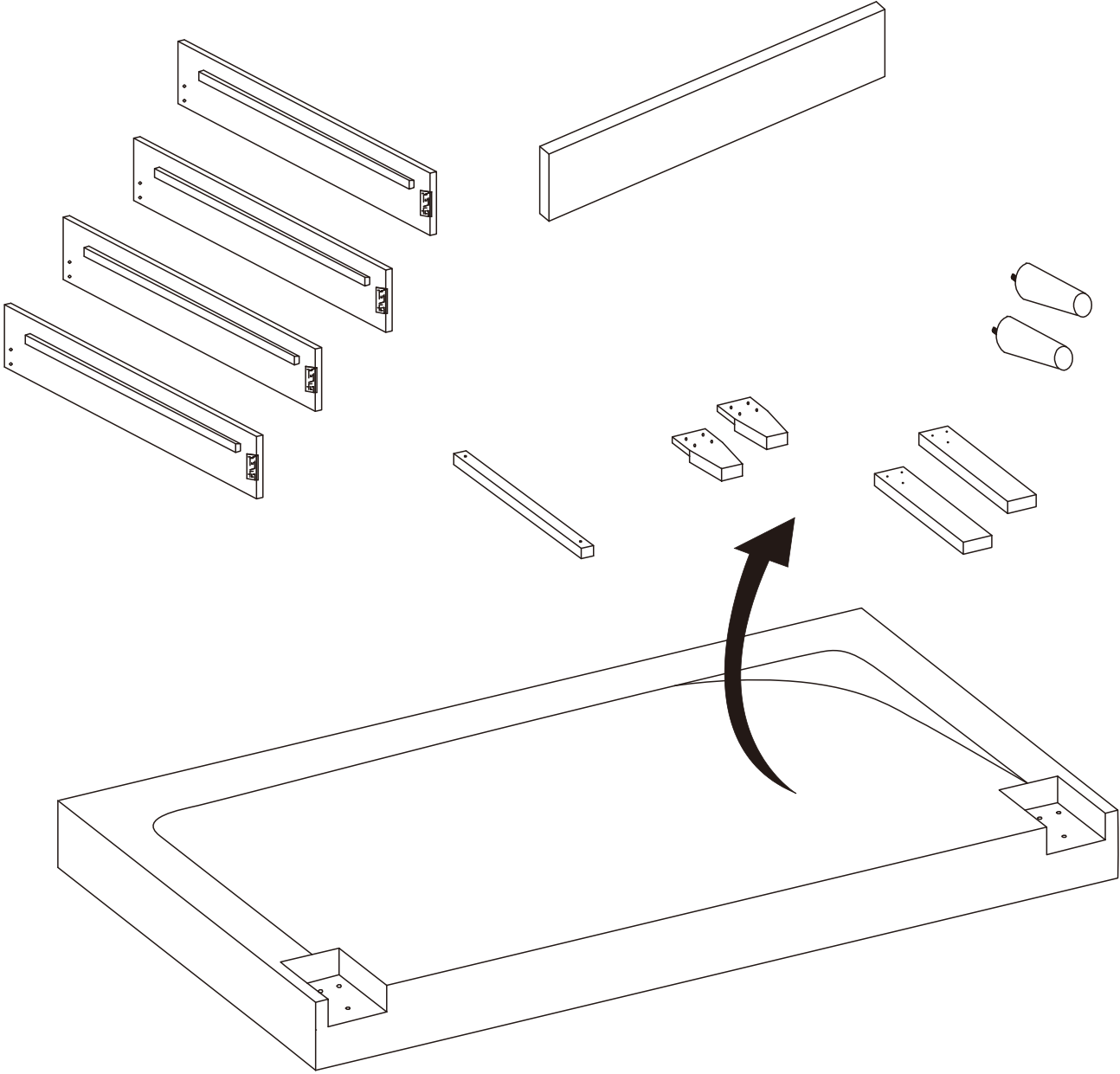

# 1

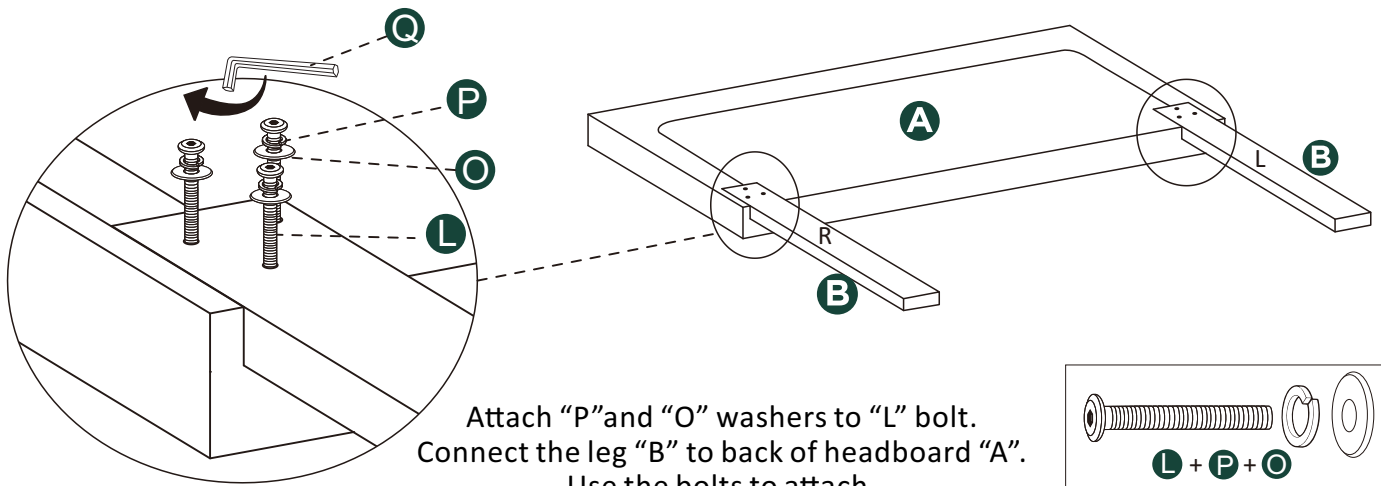

Attach "P" and "O" washers to "L" bolt.  
Connect the leg "B" to back of headboard "A".  
Use the bolts to attach.

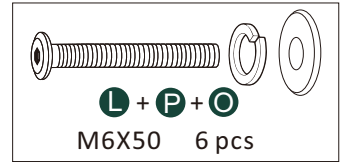

# 2

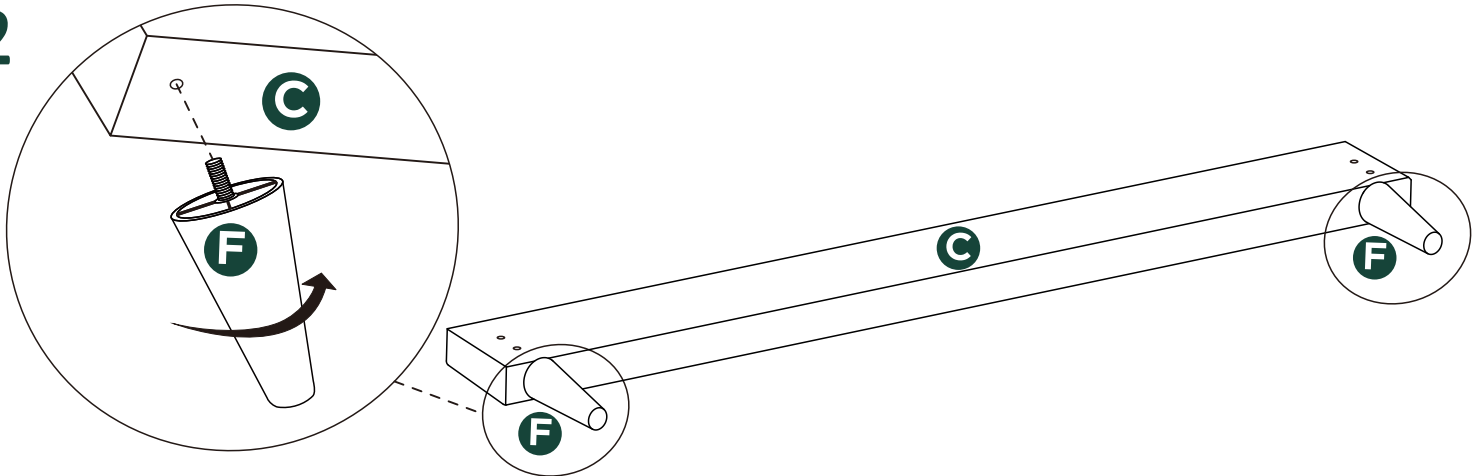

# 3

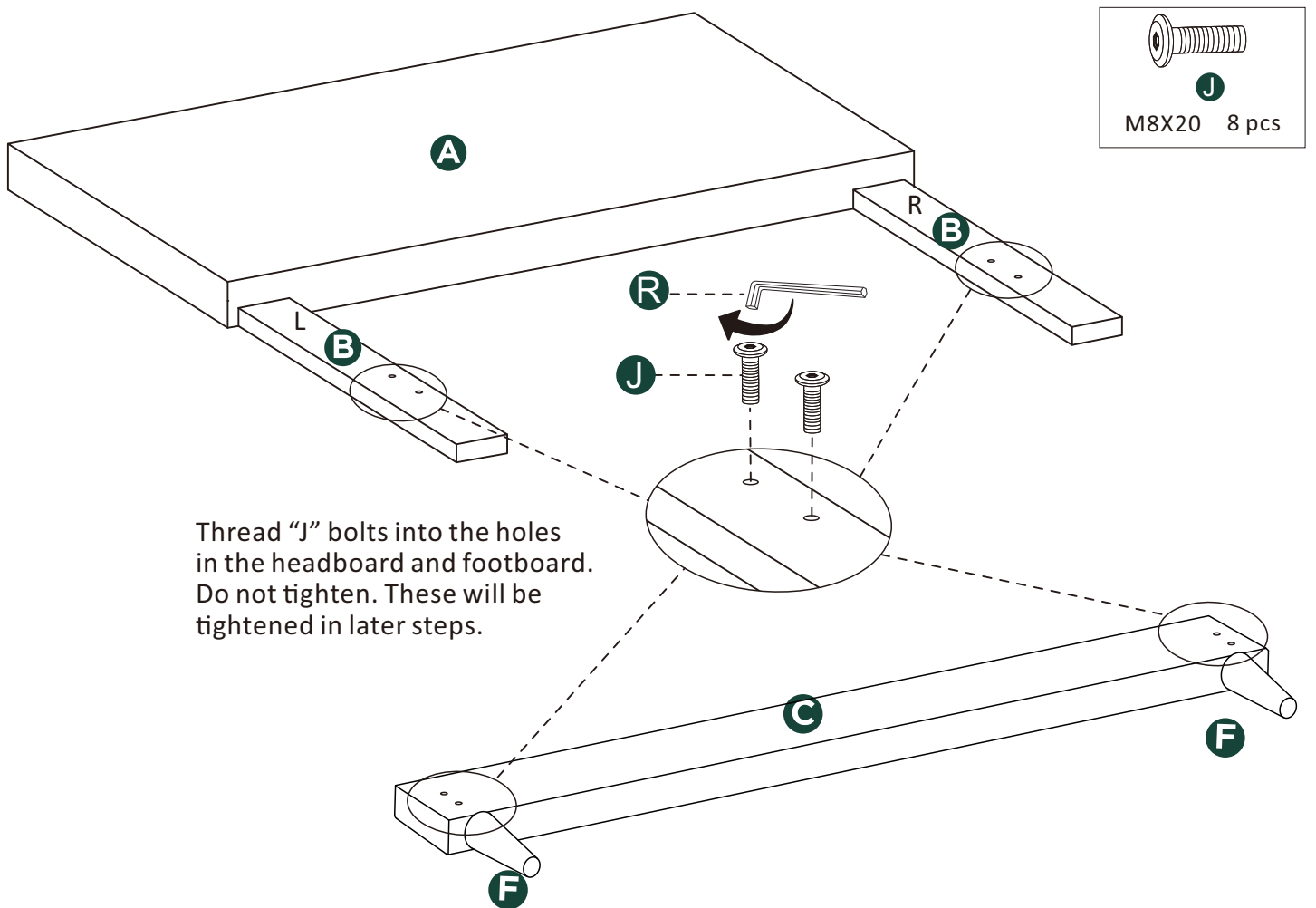

Thread "J" bolts into the holes  
in the headboard and footboard.  
Do not tighten. These will be  
tightened in later steps.

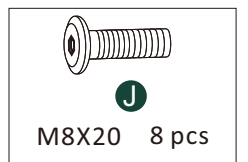

4

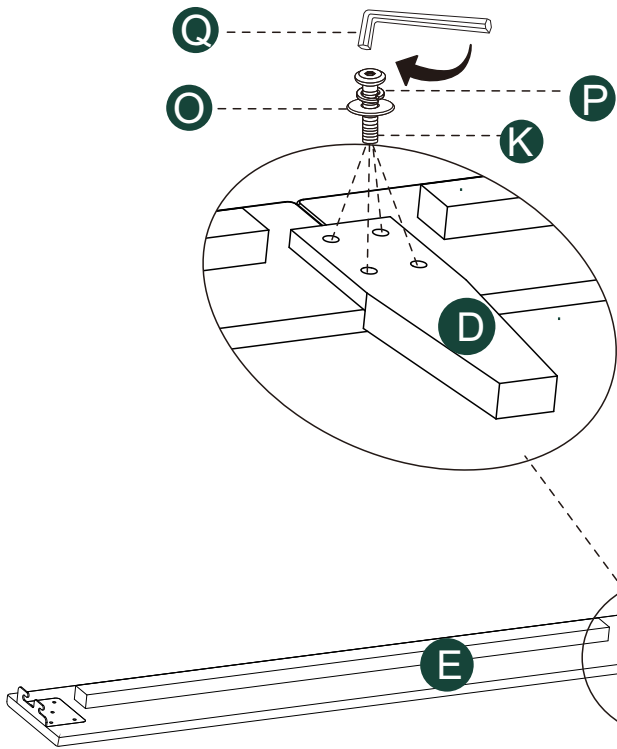
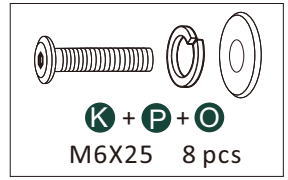

Attach "P" and "O" washers to "K" bolt.  
Connect the top and bottom of  
each side rail with a "D" side leg.  
Use the bolts to attach.

5

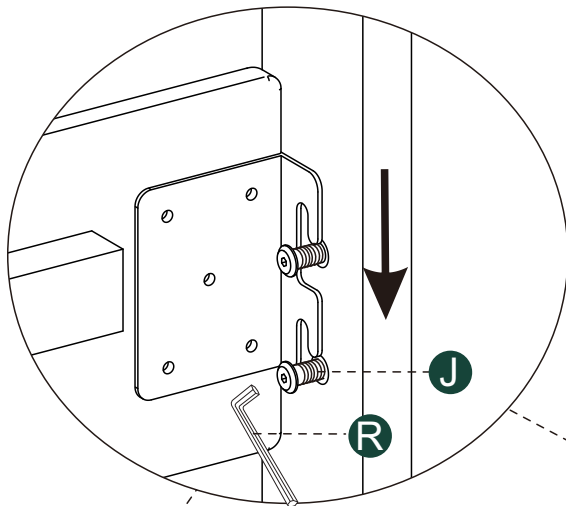

Hang the hooks at the ends of the side rails  
onto the "J" bolts in the headboard leg and  
the footboard. Tighten the "J" bolt so the  
rails are secure.

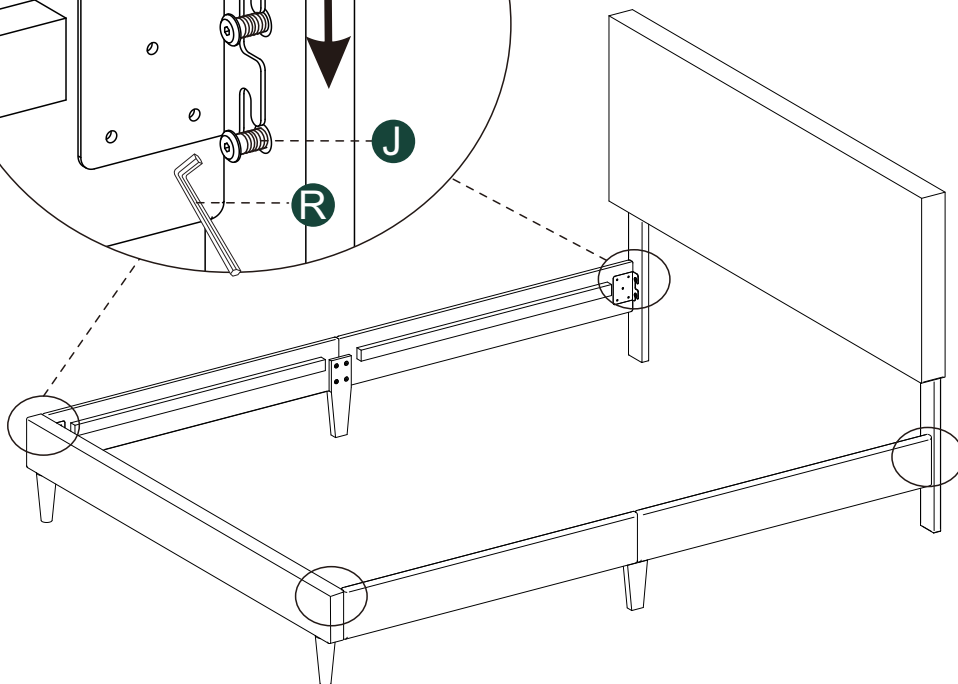

# 6

Assemble the slat system by attaching the slats to the "I" supports and "H" legs. First, extend the slats. Then, line up the holes in the slats with the holes in the "I" supports and the holes in the tops of the "H" legs. Use an "M" bolt through the holes to attach them together.

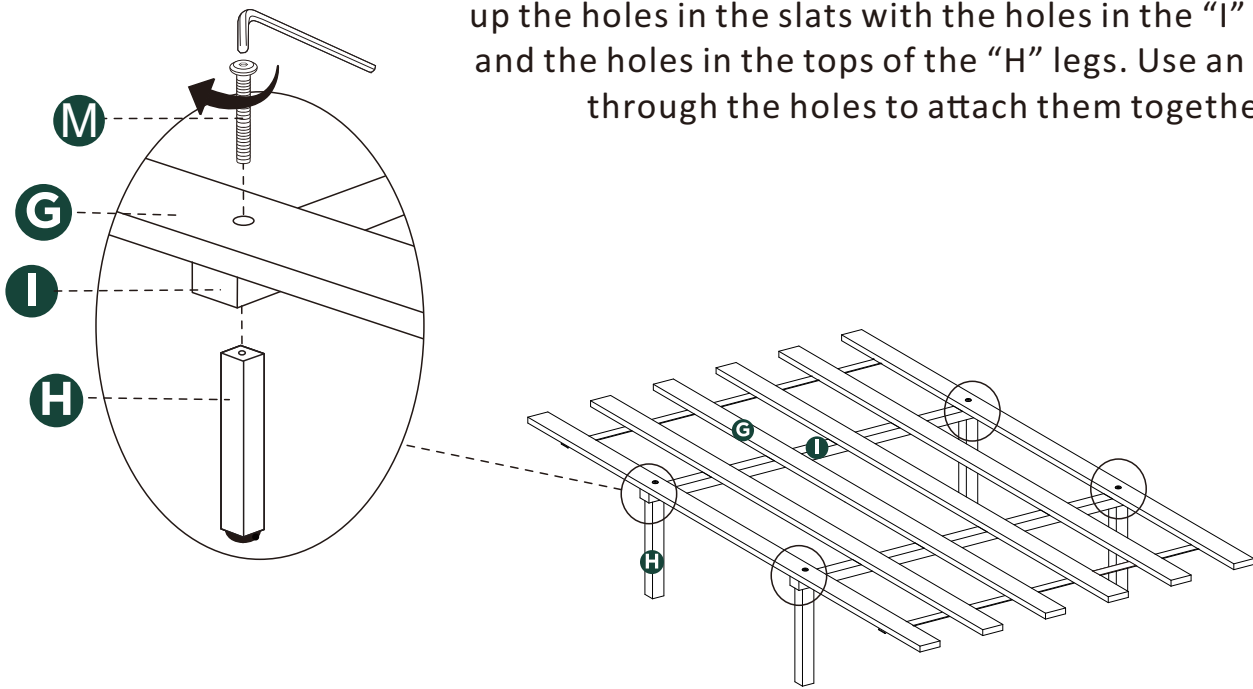

After the slat system is assembled, place the slats into the frame of the bed as shown below.

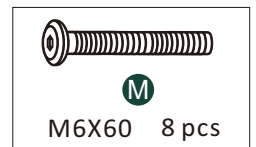

# 7

Use screwdriver to install "N" screws into side rail cleat

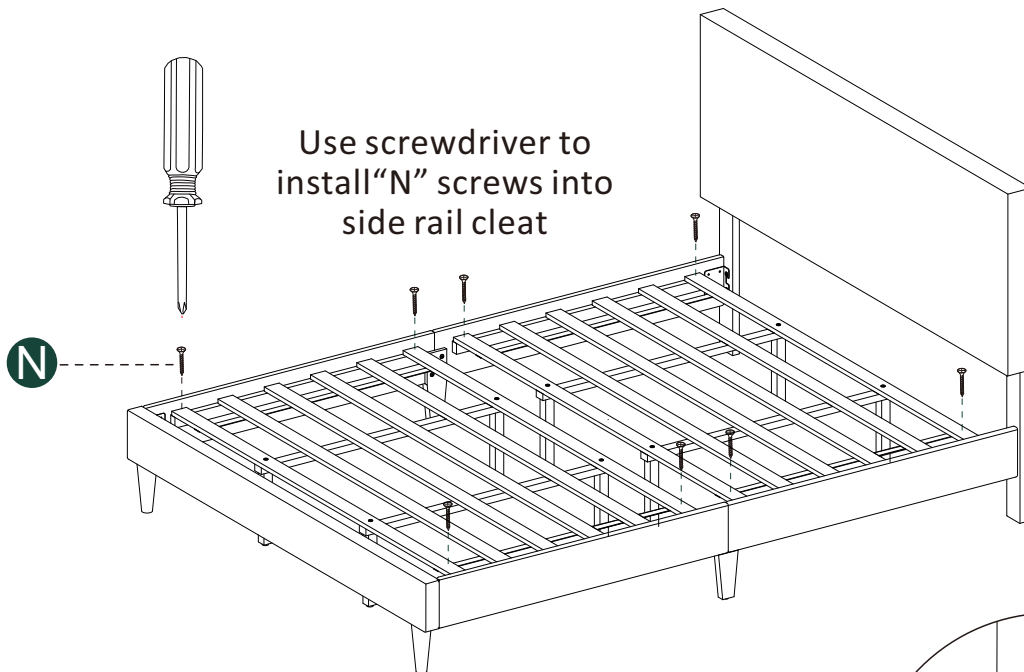

Finally, adjust slat leveling feet to touch floor

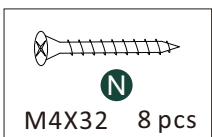
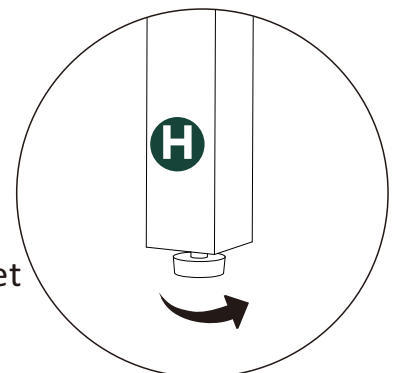

## **FOR ADDITIONAL HELP:**

---

Contact our support team at: [orders@rizebeds.com](mailto:orders@rizebeds.com)

Or call us at: 844-545-8865

### **CAUTION:**

Do not attempt to move the bed when fully assembled. This could result in damage to the rails, headboard, or footboard.

When placing furniture on non-carpeted flooring, we recommend the use of floor protection such as an area rug or furniture pads. Area rugs and padding not included with purchase.